



Burson Soloist GT4 (R-220)
Headphone Amplifier / Pre Amplifier
User Manual

Register for warranty Ref. page 11 for details



Thank You.

Everyone at Burson Audio wants to say a big thank you and congratulations for buying the Burson Soloist GT4. We truly think it's a smart choice and that it will give you many years of enjoyment and satisfaction from music.

We know you're excited to start using it, but we suggest getting to know everything your new Burson Soloist GT4 can do first. Please take a moment to read through the manual before turning the device on.



Our Philosophy

The less the equipment tampers with the music, the greater the purity and musical enjoyment become. This has been the core design philosophy of Burson Audio since 1996. If the equipment is honest and transparent, then the tempo, dynamics and tone will materialize as a natural expression of the music and it becomes unnecessary to 'flavor' the original sound. We believe that this ideal can never be achieved through the use of standard circuitry building blocks such as opamps, IC regulators or even standard transformers. Instead, we work towards this ideal through the research and development of customized solid-state circuitries that are developed specifically to suit our applications, with each and every component be pushed to their performance peak. Only then will the end result be consistent with our philosophy and standards.

Team Burson



Unpacking

After carefully unpacking your Burson Soloist GT4, inspect for any shipping damage and call your dealer immediately if any is found. Do not power on your Burson Soloist GT4 if you find shipping damage. Please save all packing materials so the unit can be quickly and safely shipped if the need arises.



The Package

- Soloist GT4 Pre Amp / DAC
- External Power Supply 24V 5A
- Remote control unit
- Hex Key / Spare Fuse / Spare IC opamps for troubleshooting



Basic Setup

Four Easy Steps to Setup Your Burson

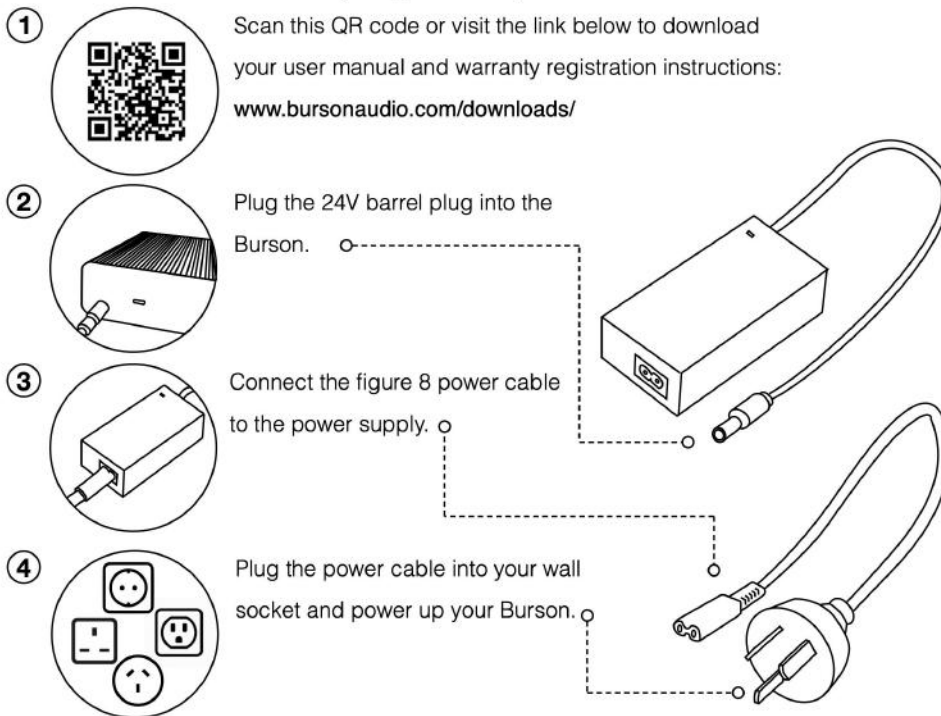

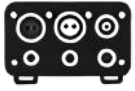

XLR to RCA Output

To achieve an ideal sonic Soloist, the Soloist GT4's XLR outputs are direct coupling, i.e., there are no coupling capacitors or transformers in the audio signal path.

However, direct coupling outputs are NOT compatible with off-the-shelf XLR to RCA adaptors like the ones shown below. Never use these types of adaptors. Using such adaptors to connect the GT4 to any single-ended amplifier with RCA inputs will damage the internal opamps of the GT4. Doing so will void the warranty.



Therefore, please only use the custom-made, Burson-marked XLR-RCA adapter in our accessories box to connect our products' XLR outputs to downstream amplifiers with RCA inputs.





Connections

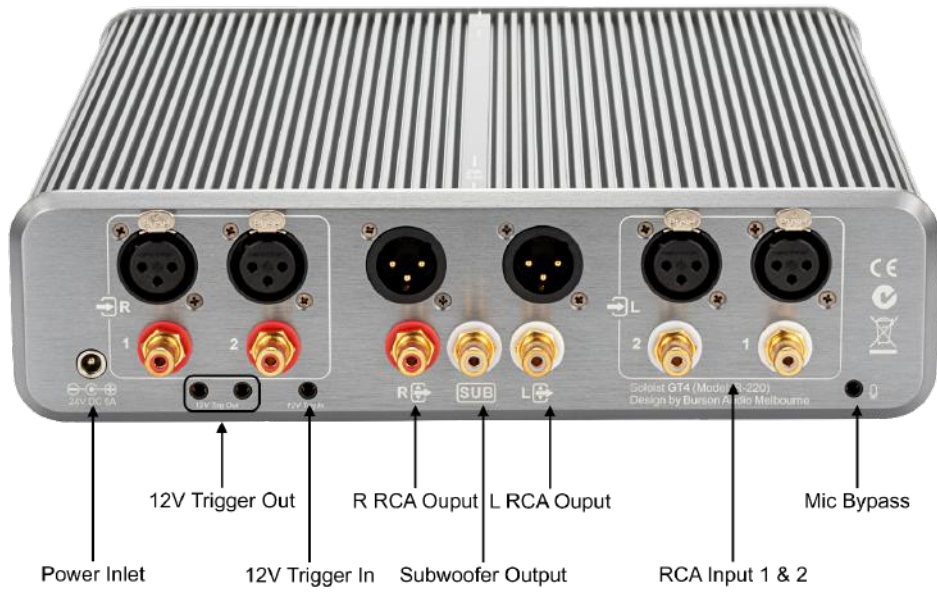



Break-in, Warm-up and Caring

The sound of the Burson Soloist GT4 improves steadily within minutes of powering up. Depending on the system's resolution and the listener's attentiveness, the sound may continue to improve over the first weeks of operation.

Never connect or disconnect the RCA or XLR output cables from the Soloist GT4 while music is playing. This could damage the Soloist GT4. Please stop the music source before disconnecting.



Menu Items

| Menu | Options | Comments |
|------------|-----------------------|--|
| Input | RCA 1 | Line level input at 2V RCA |
| | RCA 2 | |
| | XLR 1* | Line level input at 4V+ XLR |
| | XLR 2 | |
| Output | Headphone* | Headphone Amp output only |
| | Pre Amp Out | Pre Amp output only |
| | Headphone + Subwoofer | Headphone + Subwoofer output (no Pre-Amp) |
| Setting | | |
| Gain Level | High* | Full power (XLR @ 10W / SE @ 5W) |
| | Medium | 50% power (XLR @ 5W / SE @ 2.5W) |
| | Low | 10% power (XLR @ 1W / SE @ 0.5W) for IEM |
| LR BAL | 0* - 20 | 20 steps of volume adjustment to the left or right channel. This adjustment only affects Pre-Amp output. |

| | | |
|-----------|----------------------------|--|
| Crossfeed | Off* / Low / Medium / High | Three levels of crossfeed setting. |
| Remote | On/ Off* | Enable/disable the remote control function. This only applies when using multiable Burson Audio devices in a setup. |
| Reset | No* / Yes | Reset all settings to the default factory setting. |
| Auto Off | Off* / On | To comply with EU energy-saving regulations, the Soloist sleeps after 20 minutes of idling. This feature can be manually turned off from the menu. |

(*)= Default factory setting.



Changing Menu Items

- To change the menu item settings, press the Menu button to access the Menu.
- Use the rotary Volume control to scroll through the menu items.
- Select a Menu item by pressing the Volume dial inwards.
- Additional choices can be made using the scroll and select function of the Volume dial.
- Press the Menu button to remember the setting and escape from the Menu.



Opamp Upgrade

To enhance the performance of your Burson device by upgrading the opamp, kindly adhere to the following three simple steps:

Step 1: Prior to changing opamps, ensure that the amplifier is not powered. Safely disconnect the power cable from the back of the unit before proceeding to open the device and make any modifications to its internal circuitry board.



Step 2: It is crucial to note that Dual and Single opamps are distinct and cannot be interchanged. Please refer to the provided layout diagram to determine the number and type of opamps required for your specific machine configuration.

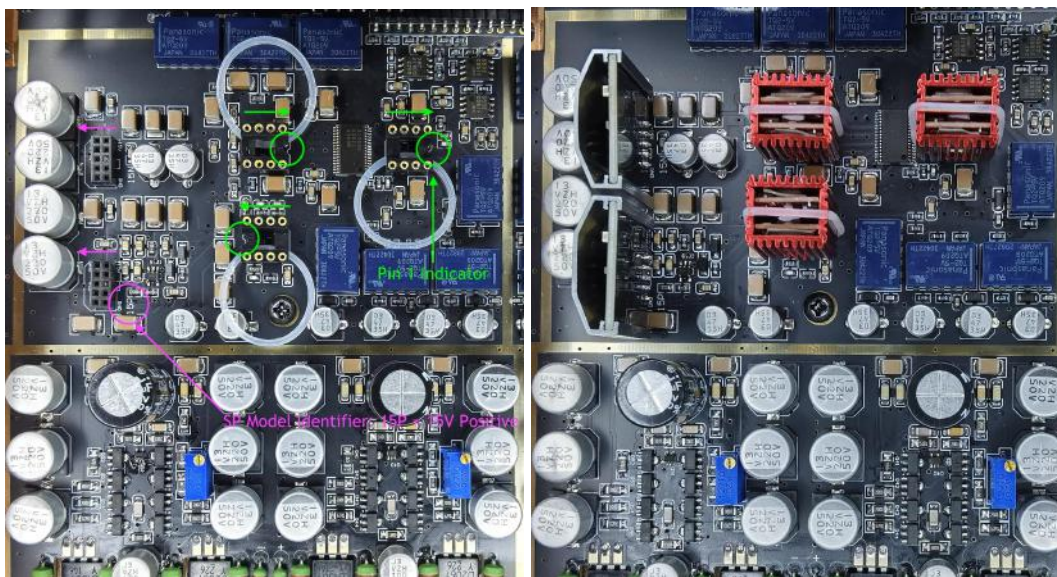

Step 3: Exercise caution while handling opamps, as they are sensitive to polarity. Plugging them in the wrong orientation can result in immediate damage. Identify the pin 1 indicator on the opamp as well as the corresponding half-moon cut on the opamp socket. Before inserting the new opamp, ensure that you have the correct orientation.

Extra Consideration: It is essential to recognise that DACs and amplifiers consist of different gain stages, such as the I/V stage, L/P stage, buffer stage, and more. When upgrading opamps, it is advisable to replace all opamps

within the same stage simultaneously. For instance, if your I/V stage currently contains two NE5532 dual opamps and you intend to upgrade them to Burson duals, it is recommended that both NE5532 opamps be replaced at once. This approach ensures the safest and most effective upgrade of your opamps.

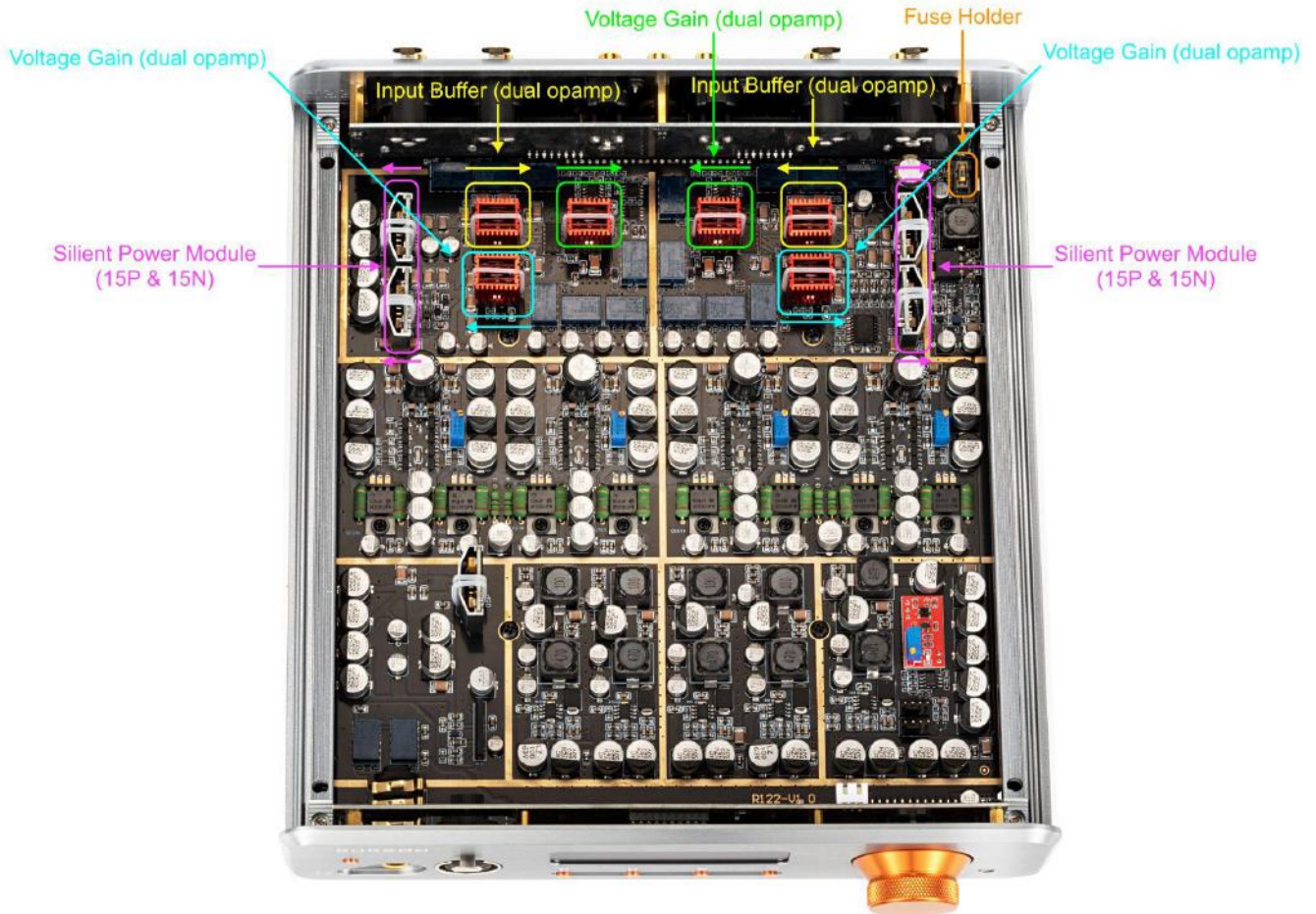

Silent Power Module Upgrade

Upgrading the SP modules even further enhances the performance of Burson products.

The table below shows our variety of SP modules:

When upgrading SP modules, please refer to our diagram or take photos of the default modules so you know where each module should be placed.

1. Identify the correct module you need for your unit. (Refer to the diagram above)
2. Look at the models already installed and compare them to the table below.

| Chipset | Noise Spec (10Hz to 100kHz) | Output Voltage | Model |
|---------|-----------------------------|----------------|---------|
| LT1963 | 40 μ VRMS | +15V | SP1-15P |
| LT3015 | 30 μ VRMS | -15V | SP1-15N |
| LT1963 | 40 μ VRMS | +5V | SP1-05P |
| LT1963 | 40 μ VRMS | +3.3V | SP1-03P |

| | | | |
|--------|----------------|-------|---------|
| LT3045 | 0.8 μ VRMS | +15V | SP2-15P |
| LT3094 | 0.8 μ VRMS | -15V | SP2-15N |
| LT3045 | 0.8 μ VRMS | +5V | SP2-05P |
| LT3045 | 0.8 μ VRMS | +3.3V | SP2-03P |



Fail-safes

If the fan is disconnected from the motherboard, if the cooling fan fails, or if the Soloist's top cover is removed, it will automatically go into sleep mode.

Before closing the top cover, please also ensure that cables or other objects do not obstruct the proximity sensor.



Maintenance

Cleaning the Soloist may be required if dust accumulates inside.

Please contact our service team to obtain detailed instructions on how to do this.



The Initial Powering up

Make sure volume control has been turned to minimal when using your Soloist GT4 for the first time. Always power on your source machine first and your power amp last. When powering down your system reverse these steps.

To select the Source - Rotate the Volume dial until the desired input is shown and press inwards to Select.



Free Warranty Extension

All Burson Audio products are covered by 24 months + 12 months of warranty (See conditions below).

<https://www.bursonaudio.com/warranty/>.



Warranty Conditions

Burson Audio warrants that this product shall be free from defects in materials and workmanship for The warranty period begins at the date of sale and is subject to the following requirements and understandings:

1. This is a non-transferable warranty.
2. This product is only warranted in the country of original sale by Burson / authorised dealer.
3. The product must not have been modified in any manner whatsoever, or the warranty is immediately voided.
4. The product must not have been stored in a humid, damp environment; nor subjected to weather, water, or salt spray.
5. During the warranty period, Burson will replace a defective Burson Soloist with a similar available product, at no cost to the owner for labour, materials, and shipping charges from Burson.
6. Burson shall not, under any circumstances, be liable for any incidental or consequential damages arising from the loss of property or other damage or losses due to the failure of a Burson Soloist3. Burson will not pay for loss of use or inconvenience caused by the failure of a Burson Soloist3. Burson will not pay for damage caused to other audio components caused by the failure of the Burson Soloist 3 within the limits allowed by Australian Law.
7. The compatibility between our USB receiver and your computer is dependent on software drivers provided to Burson by the USB chip manufacturer. Therefore Burson cannot guarantee the compatibility of our USB receiver during or after the warranty period.
8. The use of XLR to RCA adaptors will void the warranty.



Warranty Registration